

BA-481B* 1/2"-3"



Brass Ball Valve

Two Piece

Full Port

250 psig @ 250°F†

Press x Press Ends

With Extension Stem & Memory Stop

Blow-Out Proof Stem

*Not intended for use in potable water.

MATERIALS LIST

ITEM	PART	MATERIALS	ASTM SPEC.
1	Body	Brass, Forged	B283
2	Tailpiece	Brass, Forged	B283
3	Ball	CP Brass Ball	B283
4	Ball Seat	PTFE	Commercial
5	Stem	Brass	B124
6	Stem O-Ring	Buna-N	
7	Thrust Washer	PTFE	Commercial
8	Gland Nut	Brass	B124
9	Packing	PTFE	Commercial
10	Handle	Steel w/Zinc Plating	B633
11	Handle Bolt	Steel w/Zinc Plating	Commercial
12	Tube O-Ring	EPDM	D2000 NSF61
13	Stem Stop Plate	Steel w/Zinc Plating	Commercial
14	Internal Extension Tube	Steel w/Zinc Plating	Commercial
15	External Extension Tube	Steel w/Zinc Plating	Commercial
16	Upper Stem Adaptor	Steel w/Zinc Plating	Commercial
17	Memory Stop	Steel w/Zinc Plating	Commercial

*Ultra Press Valves are designed and qualified for use in copper tubing systems only, Types K & L per ASTM B88.

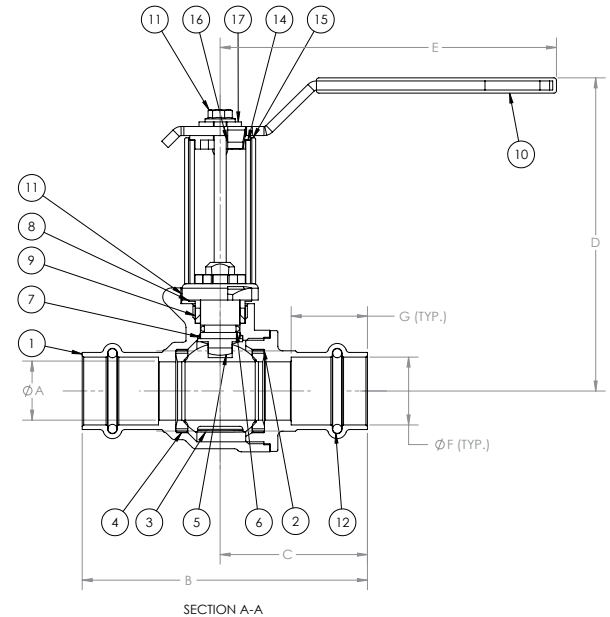

DIMENSIONS

	UNITS	1/2"	3/4"	1"	1-1/4"	1-1/2"	2"	2-1/2"	3"
		DN15	DN20	DN25	DN32	DN40	DN50	DN65	DN80
A-PORT DIA	INCHES	0.51	0.76	0.98	1.26	1.50	2.01	2.48	2.95
	mm	13	19	25	32	38	51	63	75
B	INCHES	3.16	3.71	4.28	5.20	6.31	7.44	11.92	14.07
	mm	80	94	109	132	160	189	303	357
C	INCHES	1.63	1.92	2.18	2.75	3.40	3.96	5.96	7.04
	mm	41	49	55	70	86	101	151	179
D	INCHES	3.87	4.26	4.46	4.71	4.87	5.38	6.19	6.37
	mm	98	108	113	120	124	137	157	162
E	INCHES	3.15	4.33	4.33	5.12	5.12	6.89	7.87	7.87
	mm	80	110	110	130	130	175	200	200
G	INCHES	1.52	1.73	2.31	3.16	3.49	4.28	8.17	9.86
	mm	39	44	59	80	89	109	208	250
Cv		18	40	72	112	161	287	448	645

The information presented on this sheet is correct at the time of publication. Milwaukee Valve reserves the right to change design, and/or material specifications without notice. For the Installation, Operation and Maintenance Manual (IOM) see the Technical/Service Information section on our website. For the most current information access www.milwaukeevalve.com

